



# HeaTec

The innovative boiler insulation



## Greiner PURTEC

Greiner PURTEC sets and raises the standards of insulation for warm water tanks. We focus on the requirements of the customers. We still set great store by emphasizing Research and Development activities, testing and patenting new products with better insulation properties. In an era of high energy costs and worldwide issues such as global warming, insulation is becoming more and more important. In order to contribute, we always focus on our customer's needs and new innovative technologies.

## Contact

office: Greiner PURtec GmbH  
Emesbergstrasse 33, 4643 Pettenbach, Austria  
[office.at@greiner-purtec.com](mailto:office.at@greiner-purtec.com)

production: Greiner PURtec CZ spol. s r.o.  
Komenského 895, 340 22 Nýrsko, Czechia  
[office.cz@greiner-purtec.com](mailto:office.cz@greiner-purtec.com)

[greiner-purtec.com](http://greiner-purtec.com)



# HeaTec

HeaTec is a smart solution for the insulation of boilers. Until now, the connection of the mineral wool has been created by staples. HeaTec insulation has mineral wool plates designed to be precisely fitted and connected by means of a plug connection (model puzzle).

Therefore the insulation is self-supporting (without additional material, glue, clamps, etc. to the connection) and no longer has to be attached to the boiler (no adhesive). This considerably reduces the assembly time. The simple handling of the parts also minimizes the subject of dust formation.

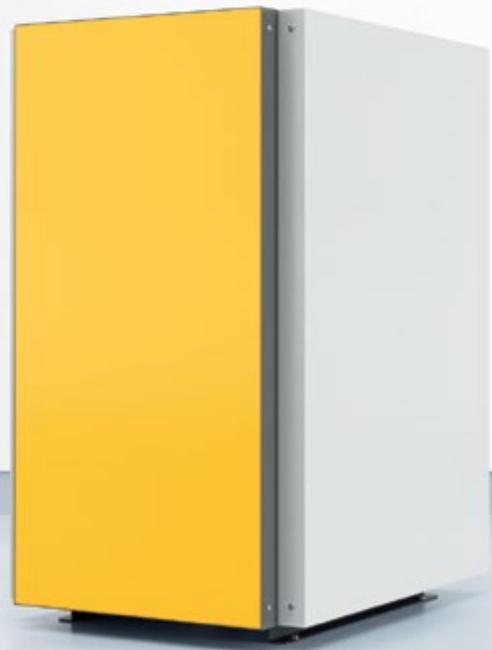

## Why HeaTec

- 1 Amazing properties.  
Good thermal insulation properties, easy and quick assembly without additional tools.
- 2 Individual solutions.  
Great value of individual development with the customer.
- 3 We love our planet, so we set an example.  
Natural material, no harmful substances.
- 4 Top quality.  
Non combustible, fire class A1. Innovative system (patented).
- 5 Technology of today, solution for tomorrow.  
We constantly innovate to meet the standards of the future.



## Puzzle principle

Whole body is made from a minimum number of pieces.  
Very small bodies can be done from just one piece of material.  
This means way simpler and faster assembly time.

The whole system is self-supporting and is delivering consistent insulating properties along the whole lifespan.

- 1 Edges are created by bending.
- 2 Bigger parts and connections are created by a simple plug.

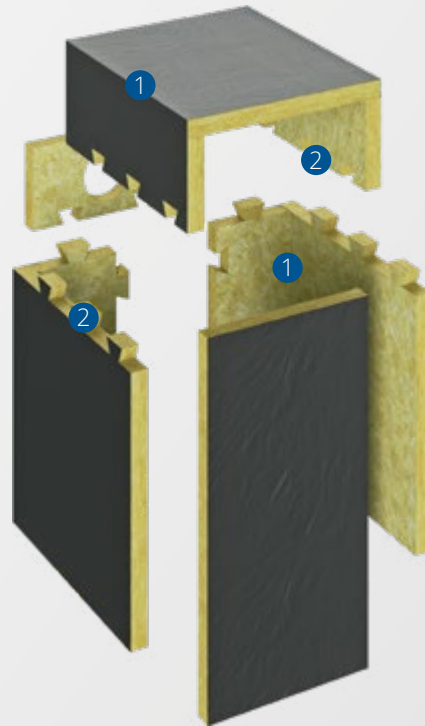

## Thermal insulation properties

High quality material is used for the insulation. The thermal conductivity depends on the density of the material which can be adapted to individual customer needs.

GRAPH: Thermal conductivity

The material density has positive impact on absorption coefficient and thus the insulating properties.

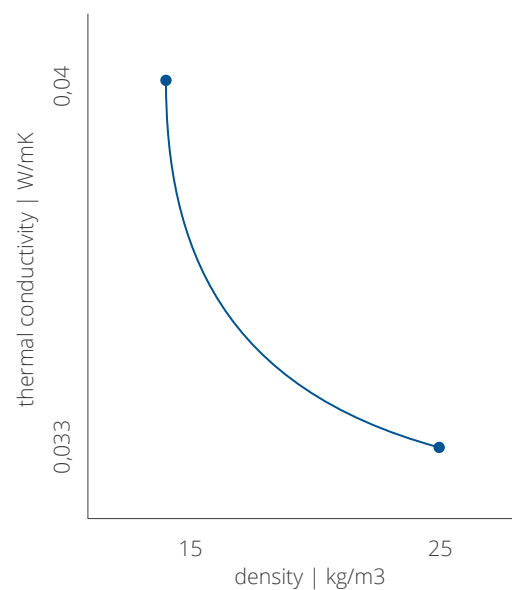

## Description

- ① Boiler

---

- ② Parts of HeaTec insulation. Bended and interlocked with puzzle plug. Together creating a self-supporting solution.

---

- ③ Door is also filled with HeaTec insulation.

---

- ④ For top layer covers are usually used profiled metal sheets.

---

- ⑤ Profiled metal sheets or PURtec cover made of PS.

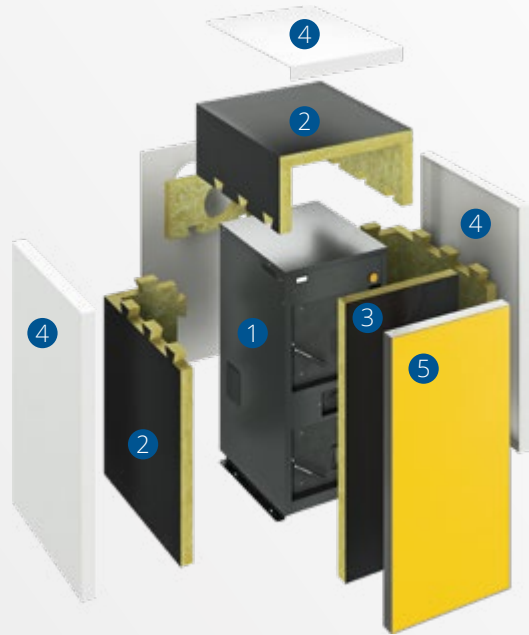

## Sustainability, ecology

The HeaTec solution is composed of 90% of natural mineral raw materials. As with other Greiner PURtec solutions, during the production of our products we focus on quality and sustainability. Our production is managed by quality standards of ISO 9001 (Quality Management) and ISO 14001 (Environmental management).

### Being responsible deserves respect

Environmentally responsible companies enjoy higher respect of clients, governments and other companies. Moreover, responsibly developed products evince the highest quality and benefits. Therefore for us at Greiner PURtec, sustainability, environmental friendliness and the highest quality go hand in hand.

### Unique approach from the start

FCKW	free
HFCKW	free
HFKW	free
other halogen gases	free
HBCD	free
unwanted fire inhibitors	free
Silicon and Silicates	free
environment protection	REACH-Konform
water stress	harmless
pH	no influence
health influence	none
recyclability	50 %

# HeaTec

This system's special feature is the interlocking of the parts, which ensures easy installation. This decisively shortens installation time and — quite incidentally — also lends an attractive appearance to the actually invisible parts.

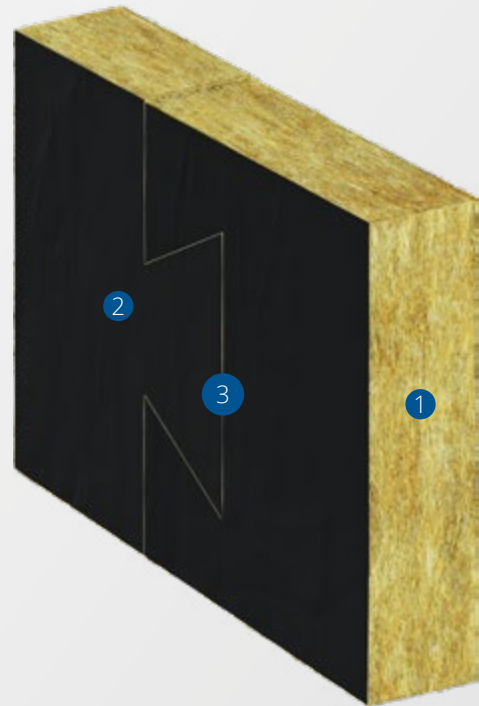

- 1 self-supporting mineral wool body
- 2 glass fiber fabric
- 3 smart interlocking solution

## Specifications

The important facts

surface	black fabric or insulation
thickness	30 - 120 mm
fastening	patented lock system
workers for installation	1 - 2
special aids or tools	no need
custom adjustments	yes

Surface finishes



black fabric



insulation

## 4 easy steps

With this 4 easy steps, 1 - 2 workers can install the insulation in just a few minutes:

- 1 Prepare all parts
- 2 Place and bend the first block
- 3 Interlock, bend and place all the parts
- 4 Place the boiler covers, finish the details

NOTE: Detailed manual is part of the delivery.

