

Modul[®] VIP

The thermal insulation for the A-class!

A



Greiner PURTEC

Greiner PURTEC sets and raises the standards of insulation for warm water tanks. We focus on the requirements of the customers. We still set great store by emphasizing Research and Development activities, testing and patenting new products with better insulation properties. In an era of high energy costs and worldwide issues such as global warming, insulation is becoming more and more important. In order to contribute, we always focus on our customer's needs and new innovative technologies.

Contact

Location Austria: Greiner PURTEC GmbH
Emesbergstrasse 33, 4643 Pettenbach, Austria
office.at@greiner-purtec.com

Location Czechia: Greiner PURTEC CZ spol. s r.o.
Komenského 895, 340 22 Nýrsko, Czechia
office.cz@greiner-purtec.com

www.greiner-purtec.com



Modul[®] VIP

Modul[®] VIP combines the highest energy efficiency with a modern and attractive design.

The insulation of hot water storage tanks up to 1,000 litre capacity has thus entered a new dimension. The minimization of heat losses amounts to up to 50 percent as compared to conventional C-class insulations.

Modul[®] VIP is delivered in four modules that can easily be joined and that work without any additional closing principle. The installation can therefore be carried out by a single person, if necessary. The tongue-and-groove closure gives the design an especially "clean" appearance.



Why Modul[®] VIP

- 1 Highest energy efficiency.
Energy efficiency class A thanks to innovative insulation concept.
- 2 Reduction of heat losses.
Maximum possible reduction of heat losses for storage tanks up to 1,000 litre capacity.
- 3 Modular design.
Pre-shaped modules and the click lock principle make assembly extremely easy – the installation can be carried out by one person alone.
- 4 Practised sustainability and cost efficiency.
Thanks to lightweight and contaminant-free design and no additional tool cost.
- 5 Today's technology for tomorrow's solutions.
Continuous research and development for shaping future standards.

Energy efficiency classes

Conventional standard insulations currently comply with energy efficiency class C. With the innovative insulation concept of Modul® VIP that combines the high-quality insulating material Neodul with innovative vacuum insulating panels (VIP), the Modul® VIP successfully achieves thermal insulation that fulfils energy efficiency class A!

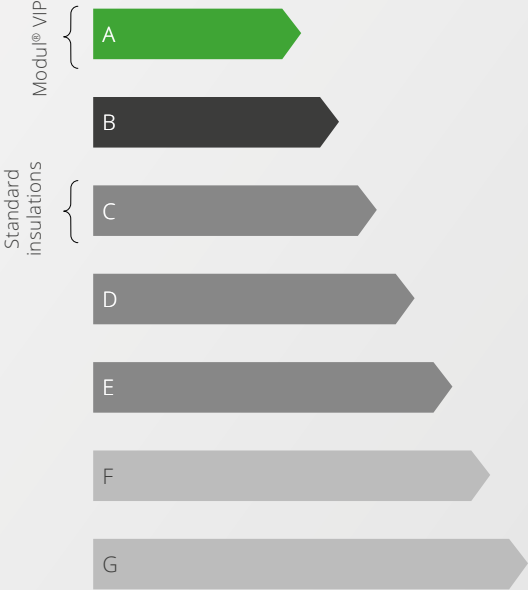

GRAPH: Energy efficiency classes comparison

Modul® VIP compared with standard insulations

Properties of the heat insulation

The minimization of heat losses for the insulation of hot water storage tanks with a capacity of up to 1,000 litres is up to 50 percent as compared to standard insulations.*

These results can be achieved due to the low heat conductivity of the insulating materials, namely 0.032 W/mk for EPS and ≤ 0.004 W/mk for vacuum insulating panels.

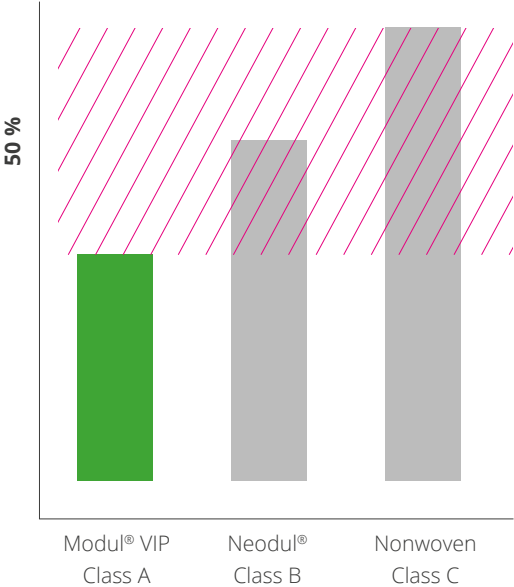

GRAPH: Comparison of insulating properties

* 50 percent less heat loss compared with standard C-class insulations

Modul® VIP

The innovative insulating concept of Modul® VIP is achieved through the use of diverse materials. A vacuum panel combined with EPS forms the basic insulation. A nonwoven inner layer protects the panel and ensures optimum adaptation to the storage tank. The outer layer consists of impact-resistant polystyrene while the closure is produced by a tongue-and-groove mechanism, with special sealing strips preventing any possible chimney effects.

- 1 EPS with graphite particles
- 2 Vacuum insulation panel
- 3 Nonwoven
- 4 Sealing strips
- 5 Tongue-and-groove joint
- 6 PS top layer

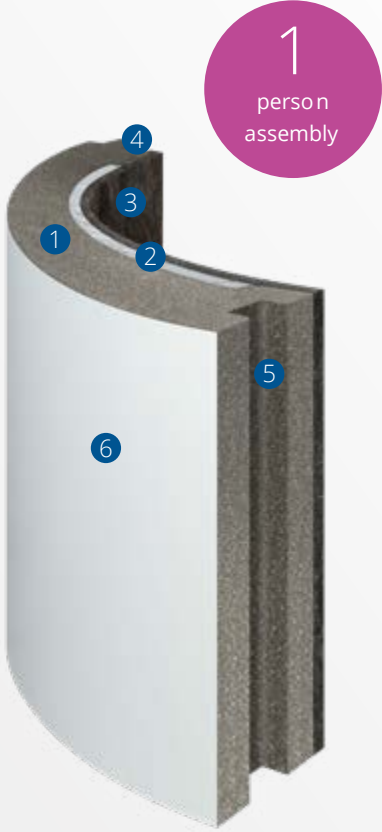

Specifications

The important facts

surface	solid PS
fastening	tongue and groove
workers for installation	1
special aids or tools	no need
custom adjustments	yes

Surface finishes

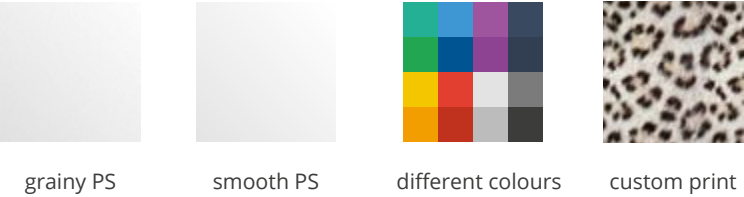

Description

- 1 The thermal insulation of Modul® VIP is composed of diverse materials. A vacuum panel combined with EPS forms the basic insulation.
- 2 A nonwoven inner insert protects the vacuum panel and ensures optimum adaptation to the storage tank.
- 3 A tongue-and-groove mechanism permits easy and quick joining of the respective panels. A special sealing strip prevents thermal bridges.
- 4 The top layer consists of impact-resistant polystyrene and is available in glossy or grained finish. Different colours or customized print can also be implemented on request.
- 5 The insulation of the lid consists mainly of EPS with a nonwoven layer for adaptability. The base insulation is made of nonwoven polyester fibre. Both are included in the delivery scope.
- 6 The top insulation finish is made of polystyrene.

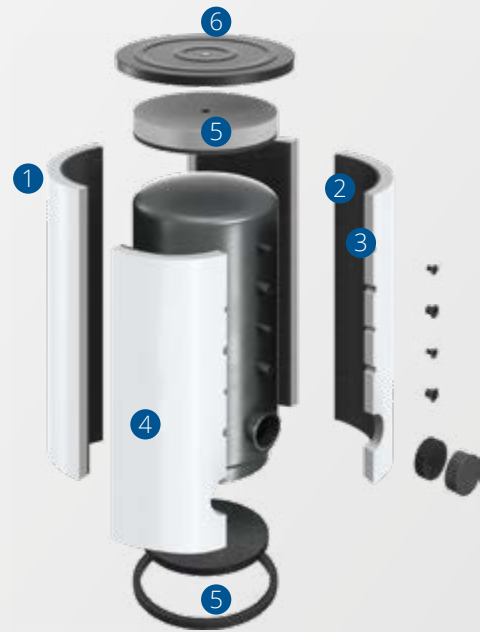

Sustainability, ecology

During the production of our products we focus on quality and sustainability. Our production is managed by quality standards of ISO 9001 (Quality Management) and ISO 14001 (Environment Protection). In the utilization phase our products maintain their properties throughout the whole life cycle, especially concerning thermal conductivity, unlike other insulation materials like polyurethane rigid foam.

At Greiner PURTEC, sustainability, environmental friendliness and the highest quality go hand in hand.

Being responsible deserves respect

Environmentally responsible companies enjoy higher respect of clients, governments and other companies. The Modul® VIP transportation leads to significantly lower CO² emissions compared to other insulation concepts, thanks to the low weight and the dimensions. It is easy to be responsible by using our solutions.

Unique approach from the start

FCKW	free
HFCKW	free
HFKW	free
other halogen gases	free
HBCD	free
unwanted fire inhibitors	free
Isocyanat	free
environment protection	REACH conformal
water stress	harmless
pH	no influence
health influence	none
recyclability	100 %

4 easy steps

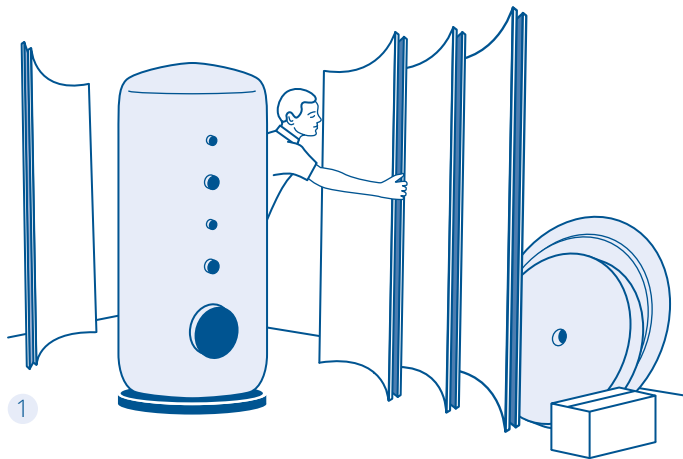

Following four easy steps, one technician can install the insulation panels on his own in just a few minutes.

- 1 Have all parts ready, mount base insulation
- 2 Arrange main parts of the insulation
- 3 Fasten main connection of the insulation
- 4 Insert lid insulation and mount accessories

NOTE: The customer will receive detailed installation instructions with the delivery.

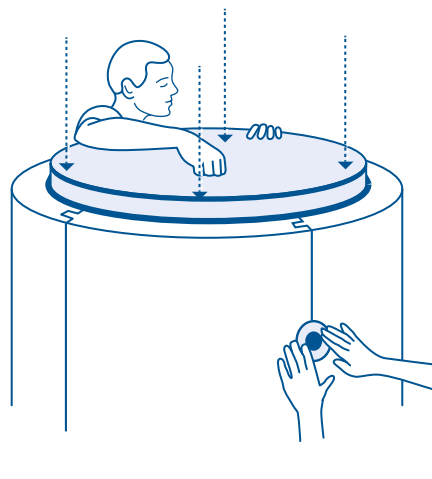
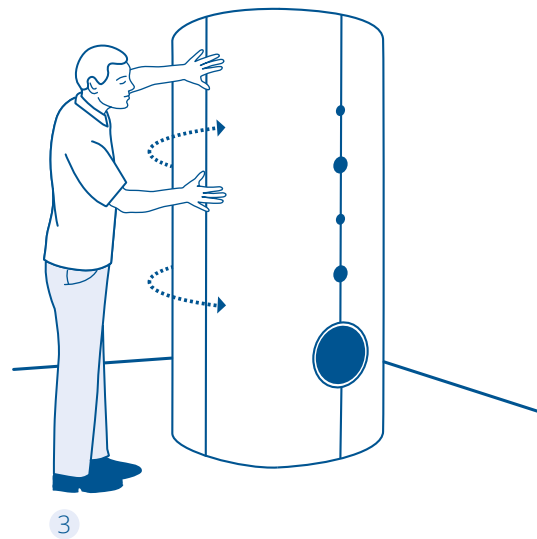
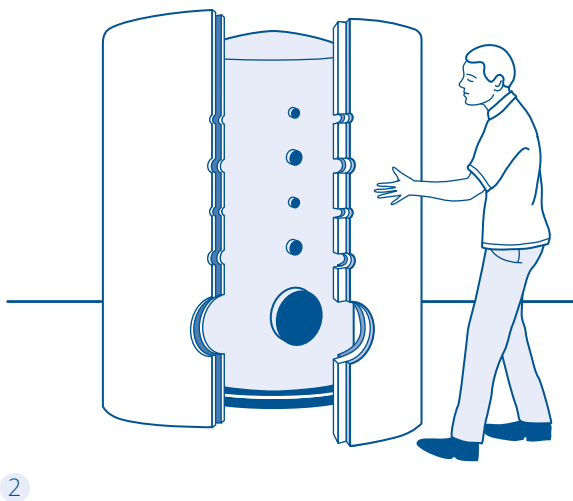



greiner
PURTEC